

 **AEROSOLV®**

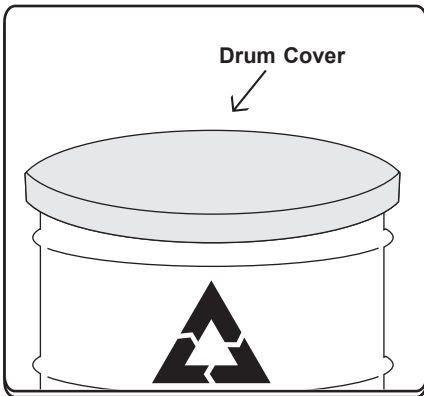

**Models**  
**7000 / 7000XL and 9000**

## Model 7000 / 7000XL / 9000 Tips

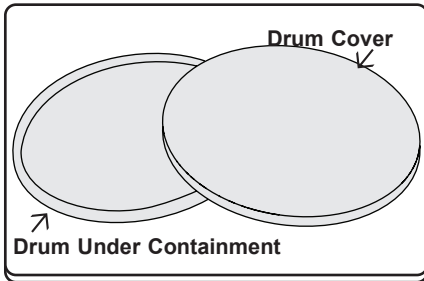

- Cover containers at the end of each workday that are used to accumulate universal waste aerosol cans for processing or shipping.

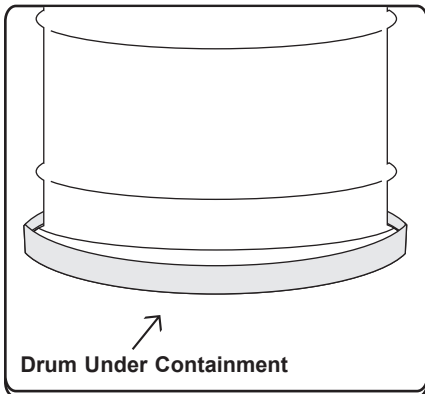

- Place the unit used to process aerosol cans above a non-earthen floor that is free of cracks or gaps and is sufficiently impervious and bermed to contain leaks and spills.

# **TABLE OF CONTENTS**

## **7000 / 7000 XL / 9000 INSTRUCTION MANUAL**

- 4** Introduction to the Aerosolv® System Can Recycling System
- 5** Aerosol Can Segregation and Characterization
- 6** Safety Instructions
- 7** Aerosolv® Unit Installation
- 7** Aerosol Can Puncturing Using the Aerosolv® Technology
- 9** Drum Capacity Determination
- 10** Aerosolv® Maintenance
- 10** Mile Marker Chart
- 11** Table 1-1 Sample Aerosol Can Segregation Scheme
- 12** Table 1-2 Recommended Aerosol Product Consolidation Scheme
- 14** Table 1-3 Aerosol Consolidation Classes
- 15** Table 1-4 Aerosol Class Compatibility Chart
- 15** Table 1-5 Aerosol Class Consolidation Chart

# INTRODUCTION TO THE AEROSOLV® AEROSOL CAN RECYCLING SYSTEM

**The Aerosolv® Aerosol Can Recycling System** simplifies aerosol can disposal, safely and efficiently. The Aerosolv® puncturing unit threads directly to the 2" bung of any 30-gallon or 55-gallon drum. Simply insert an inverted aerosol can into the Aerosolv® unit and lock the sliding top plate. With a press of the handle, a non-sparking puncture pin pierces the dome of the can. The contents are dispersed to the receiving drum; the particulate laden propellant is coalesced in the first stage of the Aerosolv® filter providing propellant flow through the Carbon cartridge.

## **The result? Recyclable scrap steel.**

After processing aerosol cans with the Aerosolv® system, you've got an empty steel can with a small, smooth-edged hole. In as little as five seconds. No spills. No jagged edges. And, no compressed gas, so it's ready for recycling with other scrap steel.

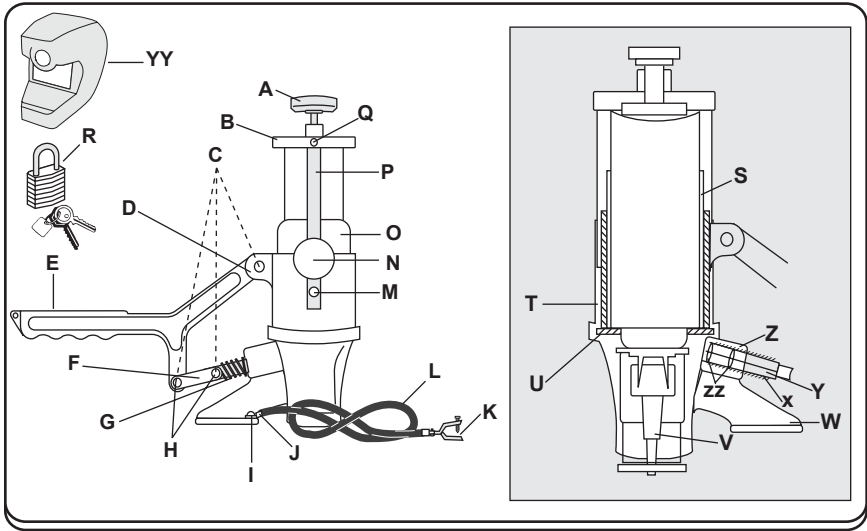

## AEROSOL CAN SEGREGATION AND CHARACTERIZATION:

Table 1-1 is provided as an example of an aerosol can segregation and characterization scheme. Users of the Aerosolv® unit may elect to use this scheme or develop their own. Aerosol products can generally be designated by one of the aerosol classes identified in Table 1-3 of the appendix. Tables 1-1 and 1-2 further define the types of aerosol products that comprise each aerosol class.



### Diagram Key

<b>A</b> - #7055 Sealing Knob	<b>P</b> - #7057 Sliding Top Plate
<b>B</b> - #7054 Cap	<b>Q</b> - #5007 Cap Rivet
<b>C</b> - #5020 Bridge Pins	<b>R</b> - #7068 Lock
<b>D</b> - #5010 Large Clevis Pins	<b>S</b> - #5018 Poly Sleeve
<b>E</b> - #7053 Handle	<b>T</b> - Aerosolv Housing
<b>F</b> - #5011 Linkage Arms	<b>U</b> - #5129 Gasket
<b>G</b> - #5012 Spring	<b>V</b> - #7070 Check Valve Assembly
<b>H</b> - #5009 Small Clevis Pins	<b>W</b> - Ground Support Plate
<b>I</b> - #5022 Brass Screw	<b>X</b> - #5012 Spring
<b>J</b> - #5410 Anti-Static Ring Terminal	<b>Y</b> - #5016EX Puncture Pin with O-Rings
<b>K</b> - #7059 C-clamp	<b>Z</b> - #5017 Teflon Sleeve
<b>L</b> - #7058 Ground Wire	<b>ZZ</b> - #5021 O-Rings
<b>M</b> - #5006 Slide Bar Rivet	<b>YY</b> - #5700 Counter <i>see Aerosolv Counter Instruction Manual</i>
<b>N</b> - #5005 Side Knob	
<b>O</b> - #5018 Poly Sleeve	



## Safety Instructions

1. Wear safety goggles while operating the Aerosolv® System.
2. DO NOT use Aerosolv® while smoking or near open flame.
3. Install Anti-Static Wire to properly “ground” drum.
4. DO NOT use Aerosolv® on a drum with less than 30-gallon capacity.
5. Remove Aerosolv® to an empty drum once collection drum is 70% full (when contents reach within 10” of the top).
6. Always engage sliding top plate and sealing knob against can being punctured.
7. Always operate Aerosolv® System outdoors or in a well ventilated area. Escaping propellants are heavier than air and may collect at point of generation.
8. When venting operation is complete, insert padlock to lock system out from unauthorized use.
9. Do not use the Aerosolv® unit for pesticides, herbicides, adhesives, or corrosive materials with pHs less than 2.0 or greater than 12.5 (i.e., Easy-Off®, corrosive acidic, and alkaline products) Comingling incompatible can contents can be hazardous. Operator must develop a segregation scheme to ensure safe operation and liquid collection.
10. Process like aerosol cans to the same collection drum for recycling (e.g., paints with paints, cleaners & degreasers with same).



## AEROSOLV® UNIT INSTALLATION

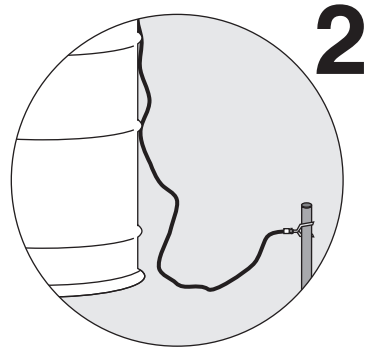

**1.** Obtain a liquid collection 30 to 55-gallon drum, poly or steel, possessing two standard bungholes: one large 2" bung hole; and one small 3/4" bunghole. Select a receptacle that is compatible with the aerosol product to be captured and inspect the receptacle for deterioration or signs of breached integrity.

Ensure the bung caps for each hole are in place. Remove the bung caps and store them in a safe place so that they may be used later. Thread the Aerosolv® unit into the 2" bunghole as illustrated. Rotate clockwise until ground support plate firmly engages drum rim. Thread combination filter into the 3/4" bung of the liquid collection drum prior to operating.

**2.** Attach C-clamp of Anti-Static wire to any nearby confirmed ground source.

*Electrical grounding must comply with the applicable state and federal regulations.*

## AEROSOL CAN PUNCTURING USING THE AEROSOLV® TECHNOLOGY:

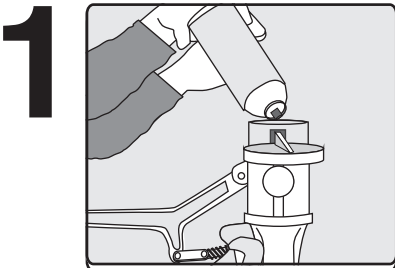

Insert aerosol can, NOZZLE END DOWN, into the Aerosolv® housing sleeve, so that the shoulder of the can rests on the internal gasket. Be sure to remove cap and bulky nozzles from aerosol can prior to insertion.

# 2

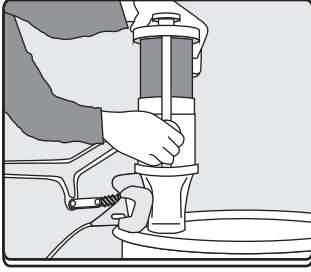

Lower sliding top plate over the bottom of the inverted can and firmly engage against plastic sleeve. Tighten the lock knob on the side of the housing. Tighten sealing knob to further depress aerosol can to internal gasket.

# 3

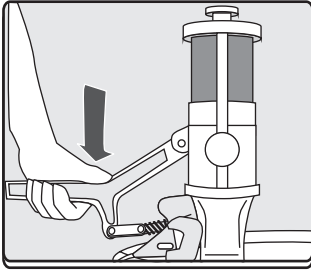

Push handle down firmly until completely depressed and hold in place while can releases initial pressure. Slowly raise the handle and immediately depress, this will control the rate of pressure and content evacuation from the aerosol can. In order to prevent backpressure, allow the contents of the can to drain into the collection drum (about 20 seconds).

# 4

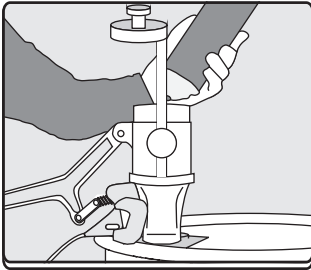

When the aerosol can's contents have been completely discharged (about 20 seconds or when can contents are obviously discharged), turn sealing knob counter-clockwise 3 rotations, unfasten the lock knob and lift the can to the brim of the Aerosolv® housing. Some residual fluid may be entrapped between the lip of the can and the

hole(s) created by the puncturing device. Tip the can to allow the residual to discharge into the unit. A rag may be used to remove any remaining residual from around the can. Remove the can from the housing, lower sliding top plate to rest on plastic sleeve to seal the collection drum, and manage the empty can appropriately.



# 5

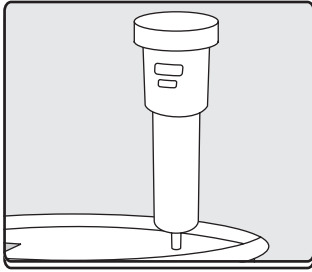

Continuously monitor the colormetric indicator to determine when the carbon in the carbon canister is approaching saturation. If the indicator indicates that the carbon is saturated, discontinue puncturing and replace the carbon canister. See Mile Marker chart (page 10) for more maintenance tips.

# 6

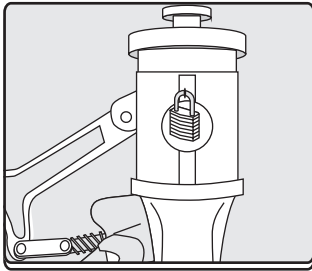

When Aerosolv® operations are complete, the unit should be locked out to avoid unauthorized use. If the collection drum is more than 70% full, secure the drum and do not return it to use. The unit may also be secured in place by inserting a padlock to prevent unauthorized use. The padlock is inserted in the through-hole located on the slide bar.

## DRUM CAPACITY DETERMINATION

The volume of liquid accumulating in the liquid collection drum should be noted prior to commencing operations. Procedures for determining when the collection receptacle is full are as follows:

- a) Obtain a ruler/dowel and a rag.
- b) Open the collection receptacle and lower the ruler into the container such that the top of the ruler is one-half inch above the rim of the receptacle bung hole.
- c) Slowly raise the ruler and inspect it to determine whether the liquid level in the collection receptacle reached the ruler level when submerged.
- d) If the liquid level in the collection container actually reached the ruler when submerged, secure the container and wipe off the ruler using the rag. If the liquid level has not yet reached the ruler, continue to puncture aerosol cans in accordance with the Aerosolv® manufacturer's operation and maintenance instructions. Repeat steps 1 through 4 to check the liquid level every 500 cans.

# AEROSOLV® MAINTENANCE

When Aerosolv® operations conclude, inspect the gasket and seals for deterioration or contamination and replace or remedy as necessary.

**• Check Valve Assembly:**

This assembly should be inspected after puncturing 1,000 cans. Remove Aerosolv® unit from collection drum and inspect for seal quality. Clean area thoroughly inside and out. Apply (3) wraps of Teflon tape to 2" threads that attach to the collection drum prior to re-installation.

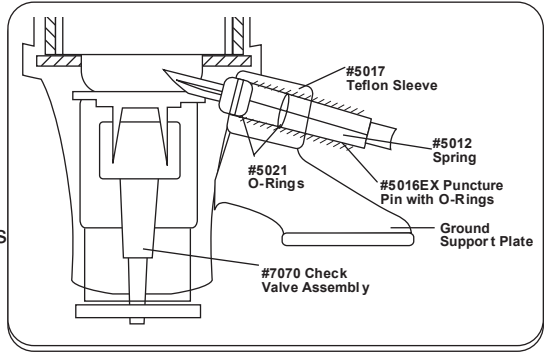

## MILE MARKER CHART

Can Count	Routine Maintenance and Filter changes
7 5 0	Replace Activated Carbon Cartridge
1 5 0 0	Replace Activated Carbon Cartridge
2 2 5 0	Replace entire Combination Filter. Remove Poly Sleeve and Gasket for cleaning and replace as necessary.
3 0 0 0	Replace Activated Carbon Cartridge
3 7 5 0	Replace Activated Carbon Cartridge
4 0 0 0 to 4 5 0 0	At this point a 55 gallon drum should be 75% full and ready for handling. Reset the counter. Mount Aerosolv system and new combination filter onto empty drum. Depending on wear, replace puncture pin, gasket, and spring utilizing the maintenance kit. Lubricate pin with lithium grease.

\*Activated Carbon Cartridge Replacement is based on prolonging the life of the Combination Filter included with the Aerosolv System. By replacing the Activated Carbon Cartridge (Upper Portion) on the Combination Filter, you will extend the use of your Combination Filter by 1500 cans.

\*Can numbers and filter replacement is based on the depressurization of spent aerosol cans (less than 20% residual liquid.) The frequent depressurization of full aerosol cans, adhesives, cold galvanizers, and co-mingling of different aerosol products may require sooner replacement of the Activated Carbon Cartridges and Combination Filters than recommended. Please see Aerosolv manual provided with system.

**TABLE 1-1**  
**SAMPLE AEROSOL CAN SEGREGATION SCHEME**

<b>Aerosol Types</b>	<b>Common Examples</b>
<b>1-</b> Ignitable solvent product w/flammmable propellant	Prestone® Starting Fluid, Keen Limited® Zeus® Butane, Malter® Dimethylsilicone Lubricant Compound, Liquid Wrench®, WD-407
<b>2-</b> Hydrocarbon product w/flammmable propellant	OMC® Anticorrosion Spray, Sprayon® Gear Lube, Panef® Lubricant with Teflon®, Zep® Cutting Oil, Solid Film Lubricant, Penetrating Fluid
<b>3-</b> Halocarbon product w/flammmable propellant	Freon 114, Degreaser
<b>4-</b> Halocarbon product w/nonflammmable propellant	Dichlorotetrafluoroethane, Freon 113, Berryman® Brake Cleaner
<b>5-</b> Hydrocarbon product w/nonflammmable propellant	Nut Buster® Penetrating Oil, Corrosion Preventative Compound, General Purpose Lubricating Oil
<b>6-</b> Toxic constituent containing product w/ flammable propellant	Enforcer® Wasp and Hornet Killer, D-trans Allethrin
<b>7-</b> Toxic constituent containing product w/ nonflammmable propellant	PT 270 Dursban®, PT 515 Wasp Freeze®, PT-240 Perma Dust®, PT-279 Engage7
<b>8-</b> Corrosive product with flammable propellant: 8A: Acidic Product 8B: Alkaline Product	Easy Off® Oven Cleaner, Degreaser
<b>9-</b> Corrosive product with nonflammable propellant: 9A: Acidic Product 9B: Alkaline Product	Oven Cleaner, Degreaser
<b>10-</b> Non-toxic product with flammable propellant	Lemon Pledge®, Glade® Air Freshener, Pam® Coating
<b>11-</b> Listed product with flammable propellant	Block Cleaner, Hi-Tech Safety Solvent® 1,1,1-trichloroethane, Sprayon® 1,1,1- trichloroethane
<b>12-</b> Listed product with nonflammable propellant	Bulk Chemical® 1,1,1-trichloroethane technical, Plaze Inc.® 1,1,1-trichloroethane technical
<b>13-</b> Paints with flammable propellants	Krylon®, Pittsburgh®
<b>14-</b> Adhesives with flammable propellants	Super 7® Adhesive Spray®, 99MA High Track Spray-AGasket 800657

**TABLE 1-2**  
**RECOMMENDED AEROSOL PRODUCT**  
**CONSOLIDATION SCHEME**

<b>Consolidation Family</b>	<b>Aerosol Types Included in Family</b>	<b>Rationale for Consolidating Types</b>
<b>1- POL: Petroleum, Oil, and Lubricants</b>	(2) Hydrocarbon product/ flammable propellant  (15) Hydrocarbon product/ nonflammable propellant	Recovered POL can be recycled and used for fuel blending. Propellants captured from POL aerosol cans are adsorbed on the activated carbon filter. Saturated activated carbon cartridges are properly disposed of as nonregulated refuse.
<b>2- Paints</b>	(13) Compatible paints	Paints are recovered and stored in appropriate containers. Recovered paints are managed as hazardous wastes and either recycled or transferred to an appropriate treatment facility. Propellants captured from paint aerosol cans are adsorbed on the activated carbon filter. Saturated activated carbon cartridges are properly disposed of as non-regulated refuse.
<b>3- Adhesives</b>	(14) Compatible adhesives	Adhesives are recovered and stored in compliant containers. Recovered adhesives are managed as hazardous waste and either recycled or transferred to an appropriate treatment facility. Propellants captured from adhesive aerosol cans are adsorbed on the activated carbon filter. Saturated activated carbon cartridges are properly disposed of as non-regulated refuse.
<b>4- Compatible Alkaline Cleaners</b>	(8B) Corrosive product/ flammable propellant  (9B) Corrosive product/ nonflammable propellant	If compatible, aqueous alkaline products from aerosol cans are recovered and consolidated with similar products. These materials can be transferred to an appropriate treatment facility. Propellants captured from these aerosol cans are adsorbed on the activated carbon filter. Saturated activated carbon cartridges are properly disposed of as non-regulated refuse.
<b>5- Compatible Acidic Cleaners</b>	(8A) Corrosive product/ flammable propellant  (9A) Corrosive product/ nonflammable propellant	If compatible, aqueous acidic products from aerosol cans are recovered and consolidated with similar products. These materials can be transferred to an appropriate treatment facility. Propellants captured from these aerosol cans are adsorbed on the activated carbon filter. Saturated activated carbon cartridges are properly disposed of as non-regulated refuse.

**TABLE 1-2 (CONT'D)**  
**RECOMMENDED AEROSOL PRODUCT**  
**CONSOLIDATION SCHEME**

<b>Consolidation Family</b>	<b>Aerosol Types Included in Family</b>	<b>Rationale for Consolidating Types</b>
<b>6- Halocarbon Solvents</b>	(3) Halocarbon product/ flammable propellant  (4) Halocarbon product/ nonflammable propellant	Recovered halocarbon solvents may be distilled and reutilized or transferred to an appropriate treatment facility. Propellants captured from halocarbon aerosol cans are adsorbed on the activated carbon filter. Saturated activated carbon cartridges are properly disposed of as non-regulated refuse.
<b>7- Ignitable Solvents</b>	(1) Ignitable solvent product/flammable propellant	Recovered ignitable solvents may be distilled and reutilized, recycled as fuel, or transferred to an appropriate treatment facility. Propellants captured from these aerosol cans are adsorbed on the activated carbon filter. Saturated activated carbon cartridges are properly disposed of as non-regulated refuse.
<b>8- Listed Products</b>	(11) Listed product/ flammable propellant  (12) Listed product/ nonflammable propellant	Listed products may be distilled and reutilized, recycled, or collected in isolated vessels and managed as listed hazardous wastes. Propellants captured from these aerosol cans are adsorbed on the activated carbon filter. Saturated activated carbon cartridges are properly disposed of as non-regulated refuse.
<b>9- Toxic Products</b>	(6) Toxic product/flammable propellant  (7) Toxic product/ nonflammable propellant	Toxic products are either recycled or managed as hazardous waste and transferred to an appropriate treatment facility. Propellants captured from these aerosol cans are adsorbed on the activated carbon filter. Saturated activated carbon cartridges are properly disposed of as non-regulated refuse.
<b>10- Non-Toxic Products</b>	(10) Non-toxic product/ flammable propellant	Non-toxic products are managed appropriately. Propellants captured from these aerosol cans are adsorbed on the activated carbon filter. Saturated activated carbon cartridges are properly disposed of as non-regulated refuse.

**TABLE 1-3**  
**AEROSOL CONSOLIDATION CLASSES**

<b>Consolidation Family</b>	<b>Aerosol Types Included in Family</b>	<b>Rationale for Consolidating Types</b>
<b>1- Petroleum Hydrocarbons (non-halogenated)</b>	(1) POL (2) Paints <sup>1</sup> (7) Ignitable Solvents (8) Listed Products <sup>2</sup> (9) Toxic Products <sup>3</sup> (10) Non-Toxic Products <sup>3</sup>	See Footnotes 1, 2, and 3
<b>2- Resinous Materials</b>	(3) Adhesives	Adhesives and other resinous coagulating materials tend to diminish the quality of otherwise recyclable solvent products. Further, these products accelerate the deterioration of process equipment.
<b>3- Aqueous Liquids</b>	(4) Alkaline Cleaners <sup>4</sup> (5) Acidic Products <sup>4</sup> (9) Toxic Products <sup>5</sup> (10) Non-Toxic Products <sup>5</sup>	See Footnotes 4 and 5
<b>4- Halocarbon Solvents</b>	(6) Halocarbon Solvents	Many petroleum products cannot be recycled when contaminated with halocarbons. Though, halocarbon solvents are compatible with and can typically be commingled with other petroleum products and solvents.
<b>5- Alkaline Products</b>	(4) Corrosive Alkaline Products	Alkaline products potentially present a threat of heat generation through acid-base or oxidation-reduction reactions.

<sup>1</sup> Paints may either be consolidated separately or consolidated with other petroleum and petroleum-based products. If the resulting waste is going to be incinerated or fuel blended (provided the paint solids do not compromise the quality of the mixture), the paints may be consolidated with other products. If the resulting waste is to be recycled or otherwise utilized, the paint should be managed independently.

<sup>2</sup> Listed petroleum and petroleum-based wastes may be commingled with other petroleum products if the resulting mixture is characterized in accordance with the Mixture and Derived from Rules (40 CFR, "261.3), and if the mixture will be either incinerated or fuel blended. Listed wastes may not be commingled with other wastes if the resulting mixture is not characterized and managed as a listed hazardous waste.

<sup>3</sup> Toxic and non-toxic petroleum products may be commingled with other petroleum products unless the resulting mixture is intended for specific recycling or reuse efforts and the addition of these products significantly diminishes the quality of the final product. Non-petroleum products may not be commingled with petroleum products.

<sup>4</sup> Aqueous acidic and alkaline products whose pH remains between 4.0 and 10.0 may be commingled as long as the constituents that comprise the solutions are compatible. Products exhibiting pHs significantly greater than 10.0 or less than 4.0 should not be commingled. Additionally, non-aqueous solutions should not be commingled with aqueous solutions.

<sup>5</sup> Aqueous toxic and non-toxic products may be commingled with other aqueous wastes provided the constituents that comprise the products are compatible with each other. The characterization of the resulting mixture must be similar to that of the products prior to introduction.

**TABLE 1-4**  
**AEROSOL CLASS COMPATIBILITY CHART**

	<b>petroleum hydrocarbons</b>	<b>resinous materials</b>	<b>aqueous liquids</b>	<b>halocarbon solvents</b>	<b>alkaline products</b>	<b>acidic product</b>
petroleum hydrocarbons	<b>yes</b>	<b>yes<sup>6</sup></b>	<b>yes<sup>7</sup></b>	<b>yes<sup>6</sup></b>	<b>no<sup>8</sup></b>	<b>no<sup>8</sup></b>
resinous materials	<b>yes<sup>6</sup></b>	<b>yes</b>	<b>no<sup>9</sup></b>	<b>yes</b>	<b>no</b>	<b>no</b>
aqueous liquids	<b>yes<sup>7</sup></b>	<b>no<sup>9</sup></b>	<b>yes</b>	<b>yes<sup>10</sup></b>	<b>yes</b>	<b>yes</b>
halocarbon solvents	<b>yes<sup>6</sup></b>	<b>yes</b>	<b>yes<sup>10</sup></b>	<b>yes</b>	<b>no<sup>11</sup></b>	<b>no<sup>11</sup></b>
alkaline products	<b>no<sup>8</sup></b>	<b>no</b>	<b>yes</b>	<b>no<sup>11</sup></b>	<b>yes</b>	<b>no</b>
acidic products	<b>no<sup>8</sup></b>	<b>no</b>	<b>yes</b>	<b>no<sup>11</sup></b>	<b>no</b>	<b>yes</b>

**TABLE 1-5**  
**AEROSOL CLASS CONSOLIDATION CHART**

	<b>petroleum hydrocarbons</b>	<b>resinous materials</b>	<b>aqueous liquids</b>	<b>halocarbon solvents</b>	<b>alkaline products</b>	<b>acidic product</b>
petroleum hydrocarbons	<b>yes</b>	<b>no</b>	<b>no</b>	<b>no</b>	<b>no</b>	<b>no</b>
resinous materials	<b>no</b>	<b>yes</b>	<b>no</b>	<b>no</b>	<b>no</b>	<b>no</b>
aqueous liquids	<b>no</b>	<b>no</b>	<b>yes</b>	<b>no</b>	<b>no</b>	<b>no</b>
halocarbon solvents	<b>no</b>	<b>no</b>	<b>no</b>	<b>yes</b>	<b>no</b>	<b>no</b>
alkaline products	<b>no</b>	<b>no</b>	<b>no</b>	<b>no</b>	<b>yes</b>	<b>no</b>
acidic products	<b>no</b>	<b>no</b>	<b>no</b>	<b>no</b>	<b>no</b>	<b>yes</b>

<sup>6</sup> Refer to recommended consolidation chart.

<sup>7</sup> Petroleum hydrocarbons are compatible with but not typically soluble in aqueous liquids. Refer to recommended consolidation chart.

<sup>8</sup> Petroleum hydrocarbons and corrosive materials are typically compatible. However, some corrosive materials are incompatible with petroleum hydrocarbons. As such, for purposes of simplicity, this chart recommends not commingling the two.

<sup>9</sup> Some resinous materials react adversely with water. This chart reflects conservative management.

<sup>10</sup> Halocarbons are compatible with but not typically soluble in aqueous liquids. Refer to recommended consolidation chart.

<sup>11</sup> Halocarbon solvents and corrosive materials are typically compatible. However, some corrosive materials are incompatible with halocarbons. As such, for purposes of simplicity, this chart recommends not commingling the two



**AEROSOLV**® **AEROSOL CAN RECYCLING**

**888-818-7114**

**aerosolv.com**